

SUPPLEMENTAL SPECIAL PROVISIONS

APPENDIX J

Railroad Controls Limited (RCL)

**“EXIT GATE MANAGEMENT SYSTEM – RECOMMENDED
LOOP INSTALLATION”**



**EGMS
STANDARDS
&
RECOMMENDED
PRACTICES**

PRIMARY LOOP LAYOUT PARAMETERS:

1. THE LOOP AND LEAD-IN SHOULD HAVE AT LEAST 50µh AND PREFERABLY 75µh OF INDUCTANCE FOR STABILITY. THE EGMS LOOP DETECTORS WILL, HOWEVER, TUNE AND RESONATE FROM 20 TO 2000µh OF INDUCTANCE.
2. ALL LOOPS FOR EGMS OPERATION SHOULD BE LIMITED TO A MAXIMUM AREA OF 144 SQUARE FEET TO PROVIDE RELIABLE DETECTION OF EGMS DESIGN VEHICLES.
3. STRIVE TO KEEP THE LOOP INDUCTANCE GREATER THAN THE LEAD-IN INDUCTANCE.
4. CALCULATE LEAD-IN INDUCTANCE @ .22µh/FOOT. THE LEAD IN LENGTH IS MEASURED FROM THE EDGE OF THE PRIMARY LOOP TO THE CABIN OR BUNGALOW.
5. CALCULATE LOOP INDUCTANCE $L = P(T^2 + T)/4$
 WHERE: L= INDUCTANCE (MICRO HENRIES)
 P= PERIMETER OF LOOP (FEET)
 T= NUMBER OF TURNS IN LOOP

6. GENERAL GUIDELINES FOR LOOP TURNS.

PRIMARY LOOP PERIMETER	NUMBER OF TURNS	LOOP INDUCTANCE
15'-26'	4	75-130µh
27'-50'	3	81-150µh
51'-100'	2	77-150µh

NOTES: INDIVIDUALLY CALCULATE LEAD-IN VS. LOOP INDUCTANCE WHEN LEAD-IN LENGTH IS GREATER THAN 340' AND INCREASE NUMBER OF TURNS TO MEET THE CRITERIA OF STEP 3 ABOVE.

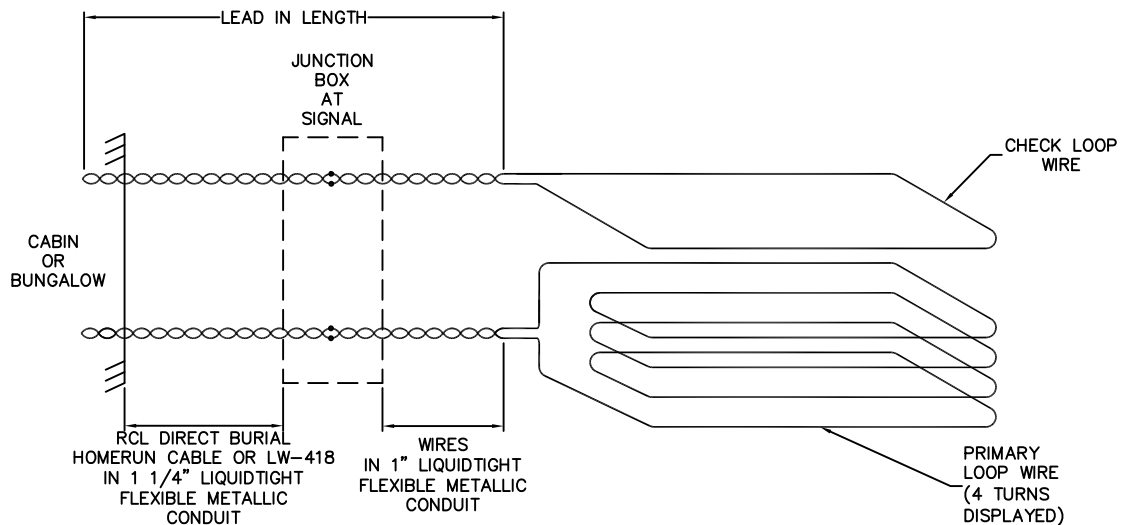

CHECK LOOP LAYOUT DESIGN PARAMETERS:

1. THE CHECK LOOP WILL CONSIST OF ONE TURN ONLY.
2. CHECK LOOP TO BE INSTALLED ABOVE THE PRIMARY LOOP TO PROVIDE ADDITIONAL MECHANICAL PROTECTION FOR THE PRIMARY LOOP.

VEHICLE DETECTION HEIGHT:

1. THE RELIABLE DETECTION HEIGHT OF VEHICLES ABOVE THE LOOP IS 2/3 THE LENGTH OF THE SHORTEST SIDE.

EXAMPLE

(6'X10' LOOP= 32' PERIMETER, 3 PRIMARY TURNS & DETECTION HEIGHT OF 4')
 (3'X20' LOOP= 46' PERIMETER, 3 PRIMARY TURNS & DETECTION HEIGHT OF 2')

RAILROAD CONTROLS LIMITED

EXIT GATE MANAGEMENT SYSTEM
 RECOMMENDED LOOP INSTALLATION

E	RJA MLH DATE: 12/17/07	D	RJA KMW DATE: 4/12/06	C	RJA KMW DATE: 3/24/06	B	RJA KMW DATE: 7/29/05	F	RJA MLH DATE: 03/24/08	A	RJA KMW DATE: 11/20/02	DRAWN: RCL DATE: 7/11/02	SCALE: NONE 1 SHEET OF 8	RECOMMENDED PRACTICE	DRAWING NO: RCL-1100.01
----------	------------------------------	----------	-----------------------------	----------	-----------------------------	----------	-----------------------------	----------	------------------------------	----------	------------------------------	-----------------------------	-----------------------------	----------------------	-----------------------------------

SPACING OF ADJACENT LOOPS WITHIN THE TRAFFIC LANE:

1. LOOPS ARE RECOMMENDED TO BE SPACED 13' OR LESS APART.
2. SPECIAL LOGIC SHOULD BE CONSIDERED FOR THE CROSSING CONTROLLER MONITORING THE LOOPS WHEN LOOPS MUST BE SPACED GREATER THAN 13' APART.

PREFORMED LOOP LAYOUT PARAMETERS:

1. LAY OUT THE PREFORMED LOOP WITH INTEGRATED CHECK LOOP TO ITS FULL SIZE (RAILROAD CONTROLS LIMITED PLC LOOP), MAY VARY IN SIZE AND CONFIGURATION.
2. USE TAPECOAT M-860 ADHESIVE TAPE (4") TO HOLD DOWN THE BENDS AT THE CORNERS OF SQUARE OR RECTANGULAR LOOPS. EXTRA LOOP ADHESIVE TAPE MAY BE USED BETWEEN CORNERS, IF NEEDED. USE ADHESIVE TAPE AS NEEDED, TO ESTABLISH AND HOLD THE CIRCULAR SHAPE OF A ROUND LOOP.
3. LOOPS INSTALLED IN NEW CONCRETE SHALL BE SUSPENDED AT LEAST 2" ABOVE THE REINFORCING BAR GRID.
4. ROUTE THE LEAD IN TO THE DESIRED TERMINATION POINT. LOOP SUPPORT CLAMPS MAY BE USED TO SECURE THE WIRE IF DESIRED.
5. POUR CEMENT OR HOT ASPHALT DIRECTLY OVER THE PRE FORMED LOOP.

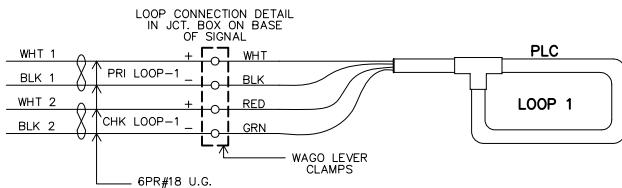
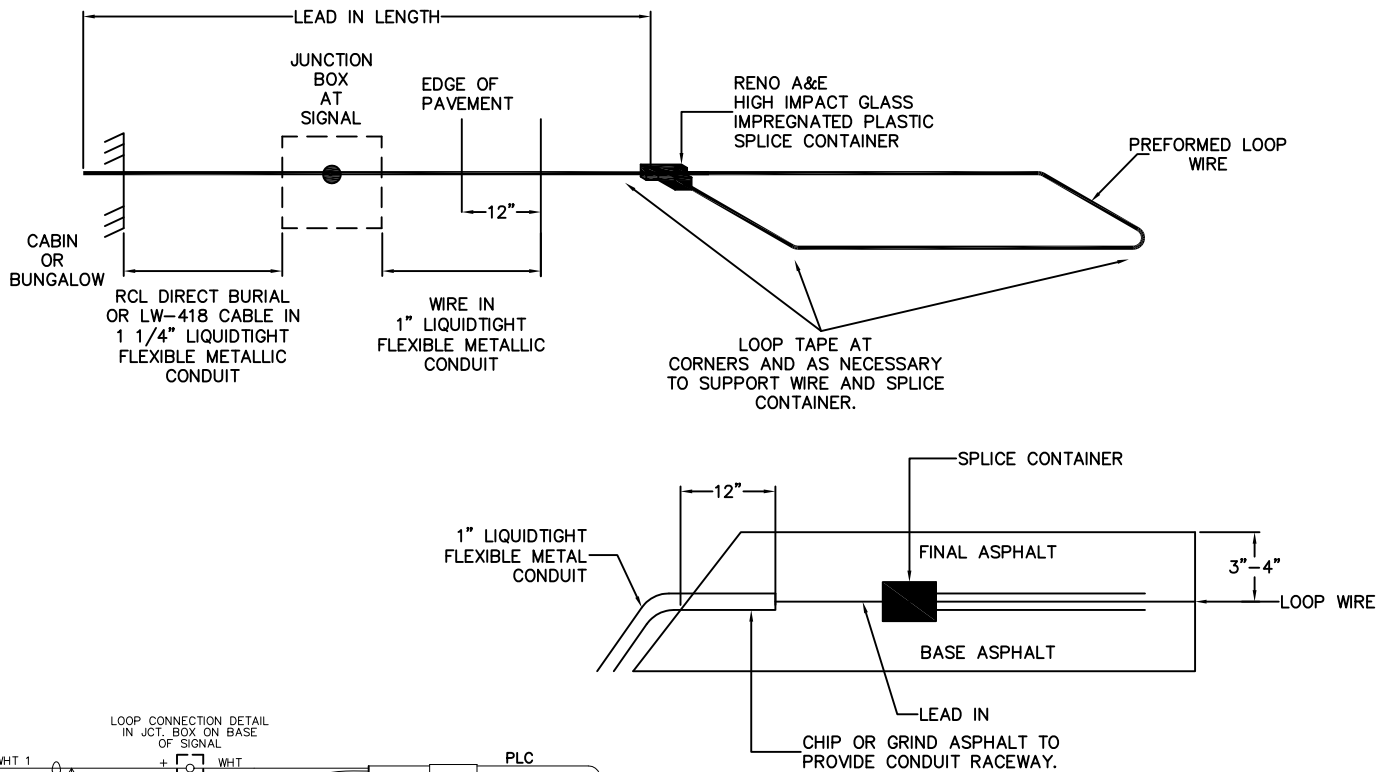

LOOP #	LOOP PERIMETER	LOOP LEAD-IN	PART #
1	'	'	PLC- -
2	'	'	PLC- -
3	'	'	PLC- -
4	'	'	PLC- -
5	'	'	PLC- -
6	'	'	PLC- -
7	'	'	PLC- -

PLC TO JUNCTION BOX ON BASE OF SIGNAL

RAILROAD CONTROLS LIMITED

EXIT GATE MANAGEMENT SYSTEM
RECOMMENDED LOOP INSTALLATION

E	RJA MLH DATE: 12/17/07	D	RJA KMW DATE: 4/12/06	C	RJA KMW DATE: 3/24/06	B	RJA KMW DATE: 7/29/05	F	RJA MLH DATE: 03/24/08	A	RJA KMW DATE: 11/20/02	DRAWN: RCL DATE: 7/11/02	SCALE: NONE SHEET OF 8	RECOMMENDED PRACTICE	DRAWING NO: RCL-1100.02
----------	------------------------------	----------	-----------------------------	----------	-----------------------------	----------	-----------------------------	----------	------------------------------	----------	------------------------------	-----------------------------	---------------------------	-------------------------	-----------------------------------

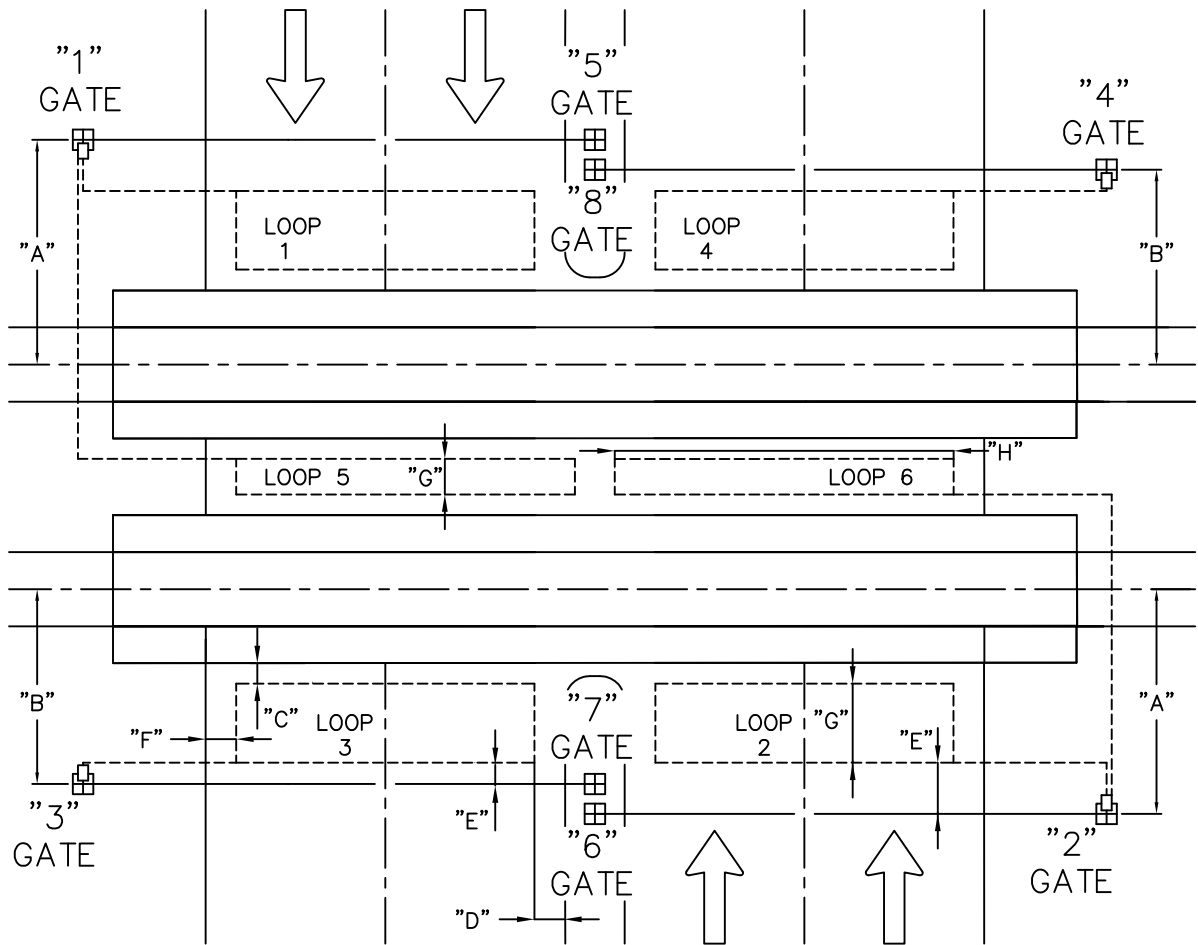

TYPICAL LOOP LAYOUT DIMENSIONS:

- "A"– TYPICALLY 15' TO MAINTAIN DIMENSIONS "G" AND "E". MAY BE REDUCED IF ENTRANCE GATES CANNOT BE RELOCATED.
- "B"– TYPICALLY 15' MAY BE REDUCED IF EXIT GATES CANNOT BE RELOCATED (SEE "E").
- "C"– TYPICALLY 12", MAY VARY FROM 6" TO 12" DEPENDING ON PAVEMENT QUALITY.
- "D"– TYPICALLY 2' FROM EDGE OF TRAVELED WAY OR LANE LINE.
- "E"– 3'-3 1/2' RECOMMENDED TO AVOID LOOP ACTIVATION WHEN A VEHICLE CROWDS UNDER AN ENTRANCE GATE. DIMENSION MAY BE REDUCED IF GATES CANNOT BE RELOCATED IN ORDER TO MAINTAIN THE 5' MINIMUM REFERENCED IN DIMENSION "G".
- "F"– TYPICALLY 2' FROM LOOP TO EDGE OF TRAVELED WAY, SIMILAR TO DIMENSION "D". MAY BE INCREASED UP TO 5' WHERE IMPROVED SHOULDER OR OTHER EXISTS OR FURTHER AS DETERMINED BY DIAGNOSTIC REVIEW.
- "G"– MAXIMUM LOOP WIDTH SHALL NOT EXCEED 8'. MINIMUM LOOP WIDTH OF ENTRANCE AND EXIT LOOPS TYPICALLY NOT TO BE LESS THAN 5'. LOOPS BETWEEN TRACKS SHALL NOT BE LESS THAN 3' WIDE.
- "H"– MAXIMUM LOOP LENGTH 28'6"
- "I"– MAXIMUM 13' BETWEEN LOOPS IN THE SAME LANE.

EXAMPLE

LOOP WIRE TAGGING:

- 1 PRIMARY LOOP– 1P1 (WHITE)
N1P1 (BLACK)
- 1 CHECK LOOP– 1C1 (RED)
N1C1 (GREEN)

NOTES:

- 1) TOTAL AREA OF LOOP SHALL NOT EXCEED 144 SQ. FT.
(EX. 8' MAX WIDTH X 18' = 144 SQ. FT.)
(EX. 6' X 24' = 144 SQ. FT.)
- 2) WHILE LOOPS MAY COVER MULTIPLE LANES, THEY SHALL NOT COVER PARTIAL LANES.

RAILROAD CONTROLS LIMITED

**EXIT GATE MANAGEMENT SYSTEM
RECOMMENDED LOOP INSTALLATION**

E	RJA MLH DATE: 12/17/07	D	RJA KMW DATE: 4/12/06	C	RJA KMW DATE: 3/24/06	B	RJA KMW DATE: 7/29/05	F	RJA MLH DATE: 03/24/08	A	RJA KMW DATE: 11/20/02	DRAWN: RCL DATE: 7/11/02	SCALE: NONE 3 SHEET OF 8	RECOMMENDED PRACTICE	DRAWING NO: RCL-1100.03
----------	------------------------------	----------	-----------------------------	----------	-----------------------------	----------	-----------------------------	----------	------------------------------	----------	------------------------------	-----------------------------	-----------------------------	-------------------------	-----------------------------------

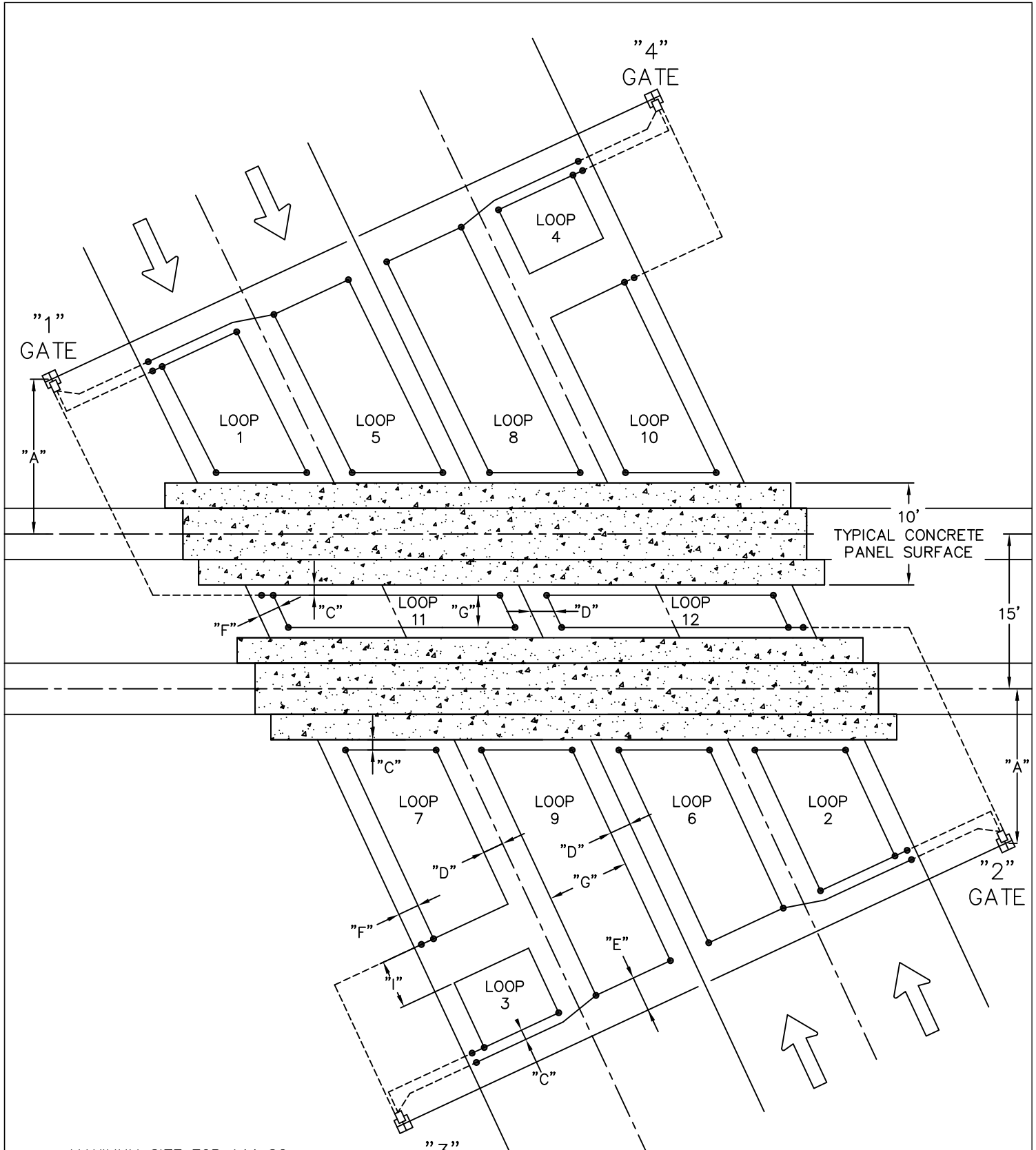

MAXIMUM SIZE FOR 144 SQ. FT. TRAPEZOID LOOP

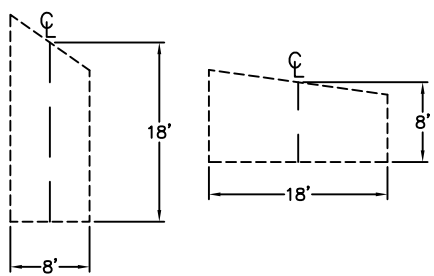

RAILROAD CONTROLS LIMITED

**EXIT GATE MANAGEMENT SYSTEM
RECOMMENDED LOOP INSTALLATION**

E	RJA MLH DATE: 12/17/07	D	RJA KMW DATE: 4/12/06	C	RJA KMW DATE: 3/24/06	B	RJA KMW DATE: 7/29/05	F	RJA MLH DATE: 03/24/08	A	RJA KMW DATE: 11/20/02	DRAWN: RCL DATE: 7/11/02	SCALE: NONE 4 SHEET OF 8	RECOMMENDED PRACTICE	DRAWING NO: RCL-1100.04
----------	------------------------------	----------	-----------------------------	----------	-----------------------------	----------	-----------------------------	----------	------------------------------	----------	------------------------------	-----------------------------	-----------------------------	-------------------------	-----------------------------------

GENERAL INSTALLATION NOTES:

1. HIGHWAY CROSSING GATES SHOULD BE INSTALLED A MINIMUM OF 15' FROM CENTERLINE OF TRACK IN ORDER TO MAINTAIN A MINIMUM TYPICAL LOOP WIDTH OF 5' (DIM "G") AND THE RECOMMENDED 3 1/2' DISTANCE FROM THE ENTRANCE GATE TO EDGE OF LOOP (DIM "E").
2. SPLICES BETWEEN THE LOOP LEAD-IN CABLE AND LOOP DETECTOR SHALL BE MADE ONLY IN THE JUNCTION BOX NEAR THE LOOP IT IS SERVING.
3. THERE ARE TWO STANDARD DIRECT BURIAL HOME RUN CABLES. LOOP DETECTOR HOME RUN CABLE SHALL BE RCL PART # 03-094-005 6PR#18AWG OR RCL PART # 03-094-003 8PR#14AWG. ALTERNATIVELY, RENO A&E LW-418 OR RR-418 MAY BE INSTALLED IN CONDUIT. REFER TO RCL CABLE BROCHURE FOR DETAILED SPECIFICATIONS. LOOP CONNECTIONS TO THE HOME RUN CABLES SHALL USE WAGO LEVER CLAMP RCL PART # 03-082-029 OR SHALL BE SOLDERED. ALL CONNECTIONS ARE TO BE SEALED TO PREVENT MOISTURE PENETRATION. LOOP CONNECTIONS SHALL BE SEALED WITH LOW MOISTURE ABSORPTION 3M SCOTCH SEAL 2229 1"X10' MASTIC OR WITH A SCOTCH CAST SPLICE ASSEMBLY.
4. THE PRIMARY AND CHECK LOOP WITH HOME RUN CABLE CONNECTED SHALL HAVE AN INSULATION RESISTANCE GREATER THAN 100 MEG OHMS UPON INSTALLATION.

SAW CUT LOOP INSTALLATION NOTES:

1. THE PAVEMENT CUT IS TO BE MADE WITH A CONCRETE SAW TO NEAT LINES AND LOOSE MATERIAL REMOVED. THE CUT SHALL BE CLEAN AND DRY WHEN THE WIRE AND SEALING COMPOUND IS PLACED. SAW CUT WIDTH TO BE SUFFICIENT TO ALLOW FREE FLOW OF SEALANT AROUND LOOP WIRE.
2. LOOP WIRE SHALL BE RENO A&E LW-116-S (.245" O.D.). 1C #16 AWG 19 STRAND COPPER WITH 0.048" XLPE INSULATION, WITH 0.030" XLPE OUTER "SLIP" JACKET FOR 0.250" SAW CUT. WHERE THE LOOP WIRE EXITS THE PAVEMENT TO THE JUNCTION BOX THE WIRES SHALL BE TWISTED TOGETHER A MINIMUM OF 5 TWIST PER FOOT. NO SPLICE SHALL BE PERMITTED IN THE LOOP OR RUN TO THE JUNCTION BOX. RENO A&E PREFORMED LOOPS MAY BE INSTALLED IN SAW CUT INSTALLATIONS.
3. ALL WIRE PLACED IN THE SAW CUT SHALL BE SEALED BY FULLY ENCAPSULATING IT IN A 3M DETECTOR LOOP SEALANT 5000 OR EQUIVALENT ROADWAY AUTHORITY STANDARD. FOAM BACKER ROD SECTIONS SHOULD BE LIMITED TO 1" IN LENGTH SPACED APPROXIMATELY 12" TO 18" APART TO RETAIN WIRE DURING LOOP SEALANT APPLICATION.
4. A SEPARATE SAW CUT SHALL BE MADE FROM EACH LOOP TO WHERE ITS CONDUIT EXITS NEAR THE EDGE OF PAVEMENT.

PREFORMED LOOP INSTALLATION NOTES:

1. WHERE ROAD SURFACE IS REPLACED, RCL PLC PREFORMED LOOPS SHALL BE INSTALLED UNDER OR WITHIN NEW SURFACE OVERLAYMENT. INSTALL PREFORMED LOOPS WITH A MINIMUM OF 3"-4" OF ASPHALT OVERLAY.

PREFORMED LOOP WILL HAVE A 3 TURN PRIMARY LOOP AND A ONE TURN CHECK LOOP. THE PRIMARY LOOP WIRES ARE WHITE AND BLACK. THE CHECK LOOP WIRES ARE RED AND GREEN. THE LOOP SHALL BE CONSTRUCTED USING A RENO A&E HIGH IMPACT GLASS IMPREGNATED PLASTIC SPLICE CONTAINER, RENO A&E LW-418 CABLE, INJECTION MATERIAL FOR THE SPLICE CAVITY, AND SOLDERED CONNECTIONS. LOOP TO BE PRE TESTED FOR LEAKAGE @ 500 VDC. SPECIFY LOOP PERIMETER AND LEAD IN LENGTH TO JUNCTION BOX WHEN ORDERING CONTACT RCL.

RAILROAD CONTROLS LIMITED

**EXIT GATE MANAGEMENT SYSTEM
RECOMMENDED LOOP INSTALLATION**

E	RJA MLH DATE: 12/17/07	D	RJA KMW DATE: 4/12/06	C	RJA KMW DATE: 3/24/06	B	RJA KMW DATE: 7/29/05	F	RJA MLH DATE: 03/24/08	A	RJA KMW DATE: 11/20/02	DRAWN: RCL DATE: 7/11/02	SCALE: NONE 5 SHEET OF 8	RECOMMENDED PRACTICE	DRAWING NO: RCL-1100.05
----------	------------------------------	----------	-----------------------------	----------	-----------------------------	----------	-----------------------------	----------	------------------------------	----------	------------------------------	-----------------------------	-----------------------------	-------------------------	-----------------------------------

LOOP SAW CUT CROSS-SECTION

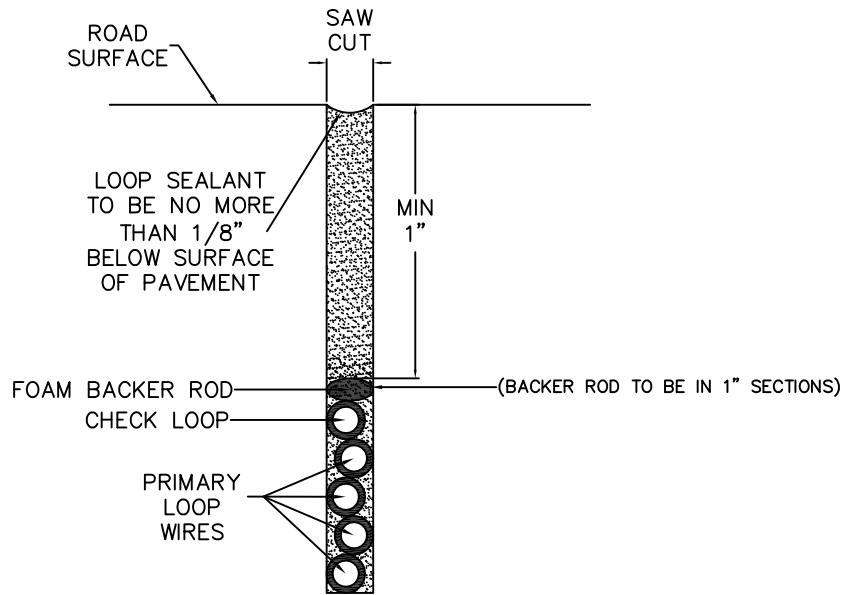

TYPICAL LOOP LAYOUTS

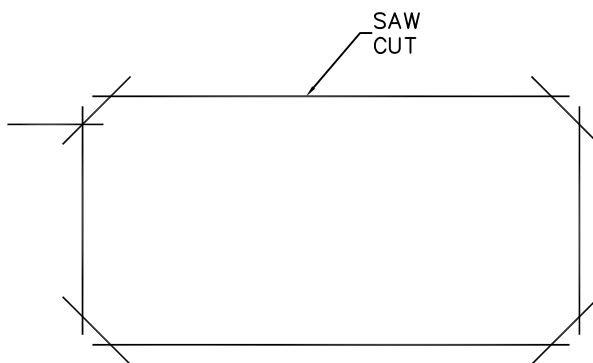
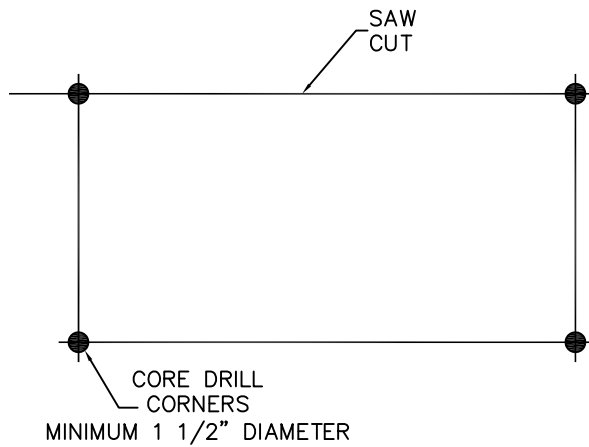

TYPICAL CORNER DETAILS

RECTANGULAR LOOP DRILLED CORNER DETAIL

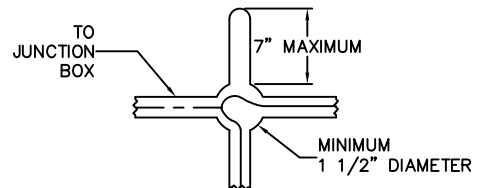

RECTANGULAR LOOP SAWCUT CORNER DETAIL

7" OVERRUN BASED ON 24" DIAMETER SAW BLADE

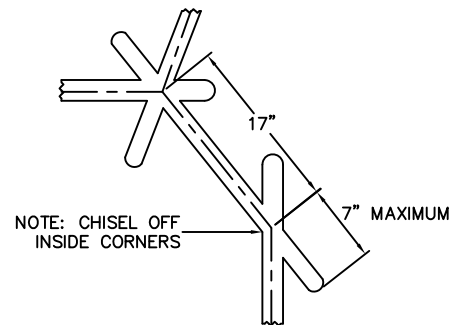

RAILROAD CONTROLS LIMITED

EXIT GATE MANAGEMENT SYSTEM
RECOMMENDED LOOP INSTALLATION

E	RJA MLH DATE: 12/17/07	D	RJA KMW DATE: 4/12/06	C	RJA KMW DATE: 3/24/06	B	RJA KMW DATE: 7/29/05	F	RJA MLH DATE: 03/24/08	A	RJA KMW DATE: 11/20/02	DRAWN: RCL DATE: 7/11/02	SCALE: NONE 6 SHEET OF 8	RECOMMENDED PRACTICE	DRAWING NO: RCL-1100.06
----------	------------------------------	----------	-----------------------------	----------	-----------------------------	----------	-----------------------------	----------	------------------------------	----------	------------------------------	-----------------------------	-----------------------------	-------------------------	-----------------------------------

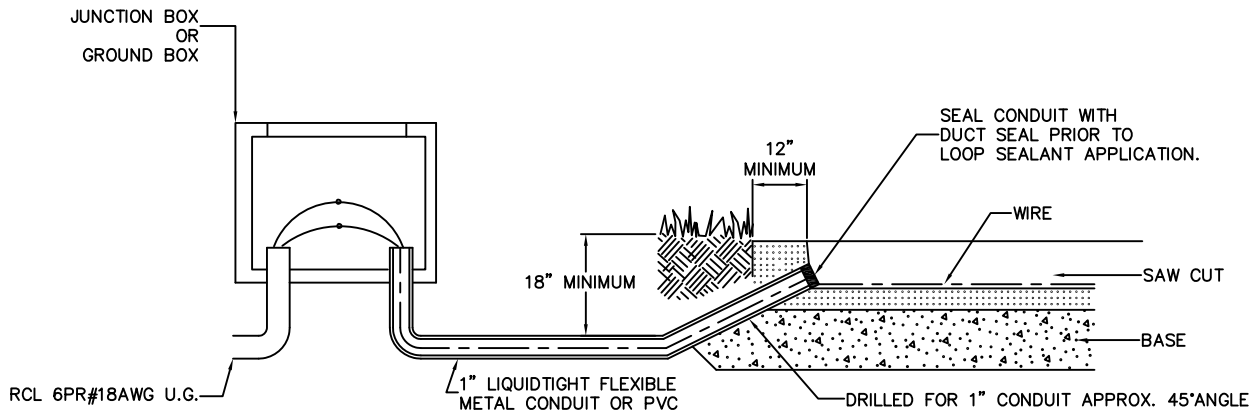

TYPICAL LEAD IN CONFIGURATION (WITHOUT CURBING)

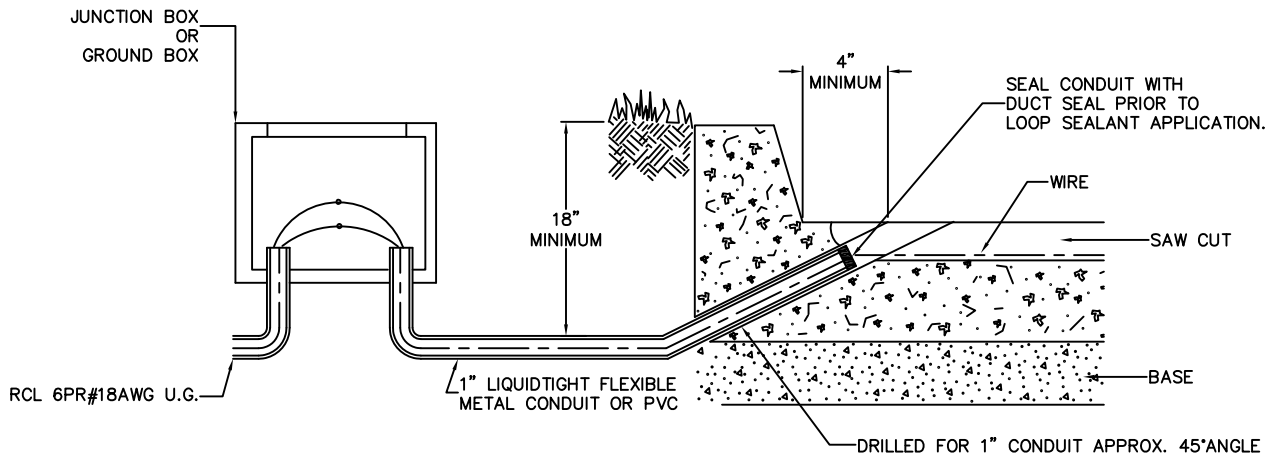

TYPICAL LEAD IN CONFIGURATION (WITH CURBING)

LOOP TERMINATION JUNCTION BOX
RCL PN 525-1000-01

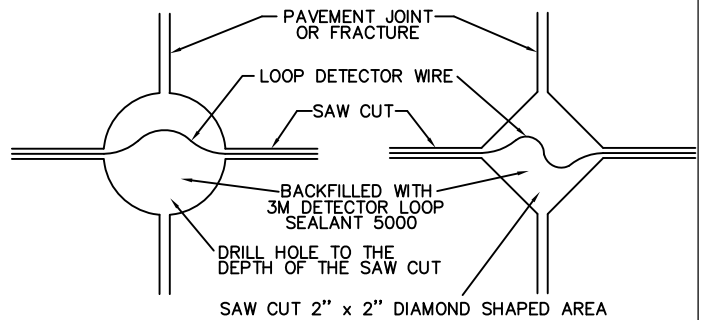
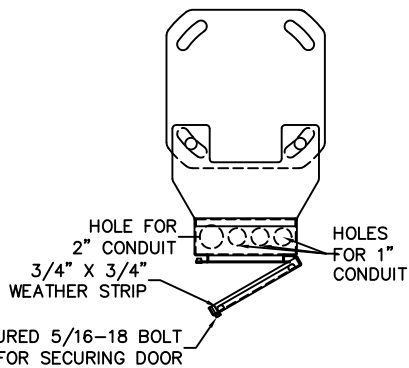

LOOP WIRE CROSSING AT EXPANSION JOINT OR FRACTURE

RAILROAD CONTROLS LIMITED

EXIT GATE MANAGEMENT SYSTEM
RECOMMENDED LOOP INSTALLATION

E	RJA MLH DATE: 12/17/07	D	RJA KMW DATE: 4/12/06	C	RJA KMW DATE: 3/24/06	B	RJA KMW DATE: 7/29/05	F	RJA MLH DATE: 03/24/08	A	RJA KMW DATE: 11/20/02	DRAWN: RCL DATE: 7/11/02	SCALE: NONE 7 SHEET OF 8	RECOMMENDED PRACTICE	DRAWING NO: RCL-1100.07
----------	------------------------------	----------	-----------------------------	----------	-----------------------------	----------	-----------------------------	----------	------------------------------	----------	------------------------------	-----------------------------	-----------------------------	----------------------	-----------------------------------

DIMENSION "LETTER"	PROPER DIMENSION IN FEET AND INCHES
"A"	
"B"	
"C"	
"D"	
"E"	
"F"	
"G"	
"H"	
"J"	
"K"	
"L"	
"M"	
"N"	
"P"	
"R"	

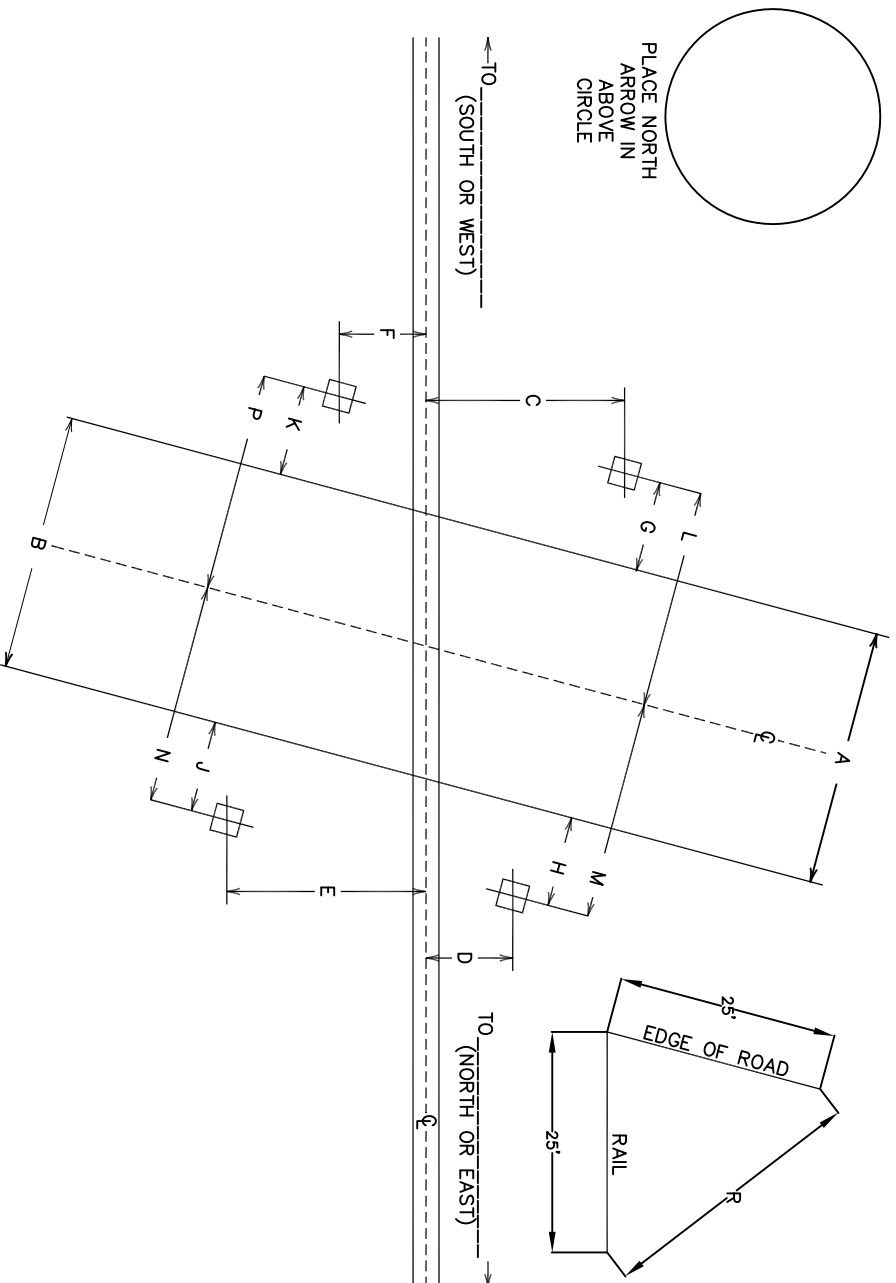

- NOTES:
- 1) IDENTIFY NORTH WITH NORTH ARROW
 - 2) FILL IN PROPER DIMENSIONS
 - 3) TO ACQUIRE THE "R" DIMENSION THIS MEASUREMENT MUST BE DONE IN THE ACUTE ANGLE OF THE CROSSING. ALL MEASUREMENTS POINT OF ORIGIN WILL BE THE INTERSECTION OF THE RAIL AND THE EDGE OF ROAD. MEASURE 25' ALONG THE EDGE OF ROAD AND MARK, MEASURE 25' ALONG THE EDGE OF RAIL AND MARK, MEASURE THE DISTANCE BETWEEN THE TWO MARKS AND RECORD FOR DIMENSION "R".
 - 4) IF CROSSING CONTAINS MULTIPLE LANES, MULTIPLE TRACKS OR ANY OTHER ODDITIES, INCLUDE SKETCH OF CROSSING INCLUDING PROPER DIMENSIONS SUCH AS ALL LANE WIDTHS AND DISTANCE BETWEEN TRACK CENTERS.
 - 5) ANY HAND DRAWN SKETCHES SHOULD BE PLACED ON THE BACK OF THIS SHEET.

STREET NAME - _____
 CITY - _____
 STATE - _____
 M.P. - _____
 RAILROAD - _____
 SUB - _____

E	RA MIA	D	RA KAW	C	RA KAW	B	RA KAW	A	RA KAW
DATE: 12/17/07		DATE: 4/12/06		DATE: 3/24/06		DATE: 7/29/05		DATE: 11/20/02	

RAILROAD CONTROLS LIMITED

EGMS DETECTOR LOOP
LAYOUT WORKSHEET

DRAWING NO. **RCL-1100.08**